

D3110002

Peso	1,752 Kg/m
Sup. in vista	197 mm

I_x (cm ⁴)	I_y (cm ⁴)	W_x (cm ³)	W_y (cm ³)	Descrizione
119,53	3,52	11,89	2,58	PROFILATO SOGLIA RIBASSATA MONOBINARIO

SEZIONE 1 - NODO INFERIORE ALZANTE SCORREVOLE MONOBINARIO

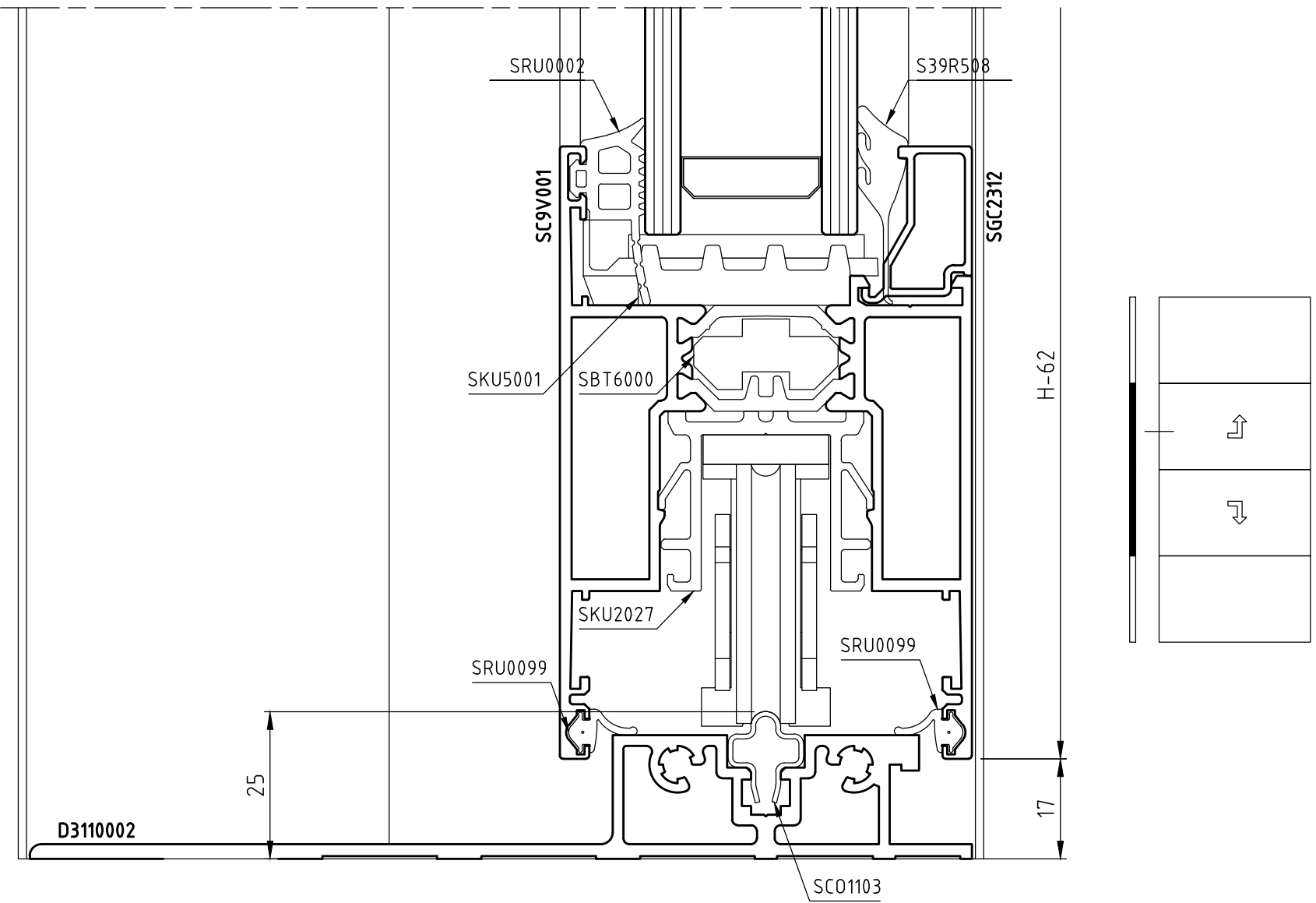

DESCRIZIONE	ACCESSORI	ATTREZZATURA
LAVORAZIONE TELAIO MONTANTE PER SOGLIA D3110002	STG9011	Pantografo

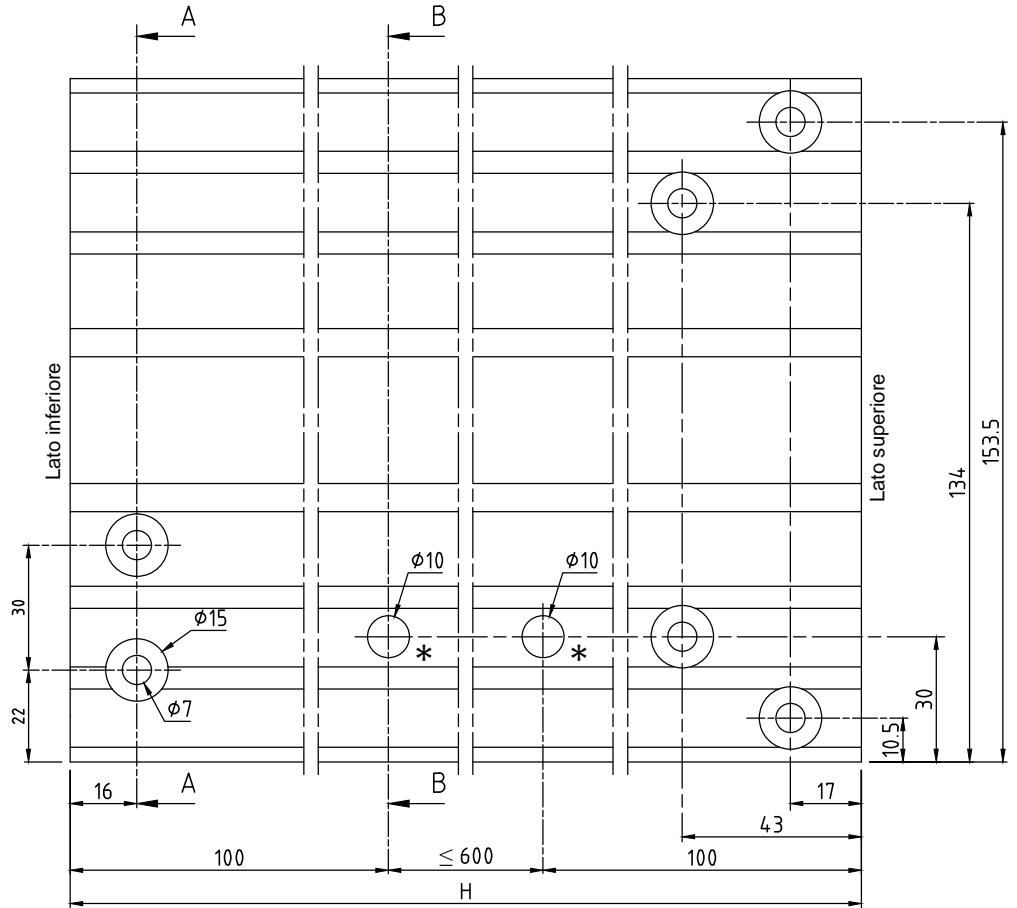
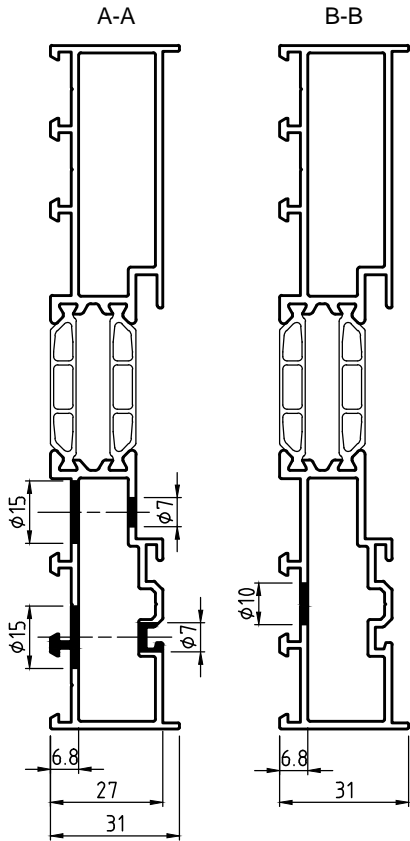

* Fori per fissaggio profilato SC9A100

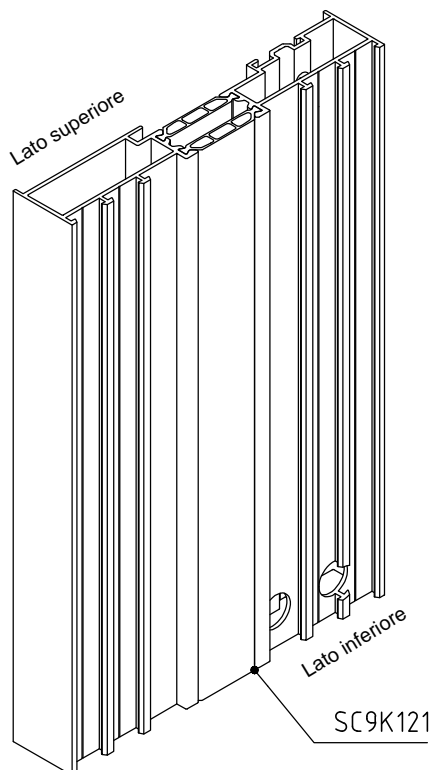

Nota: Disegni fuori scala

DESCRIZIONE	ACCESSORI	ATTREZZATURA
ADATTAMENTO ACCESSORI ESISTENTI	SC00132 SVS9957	

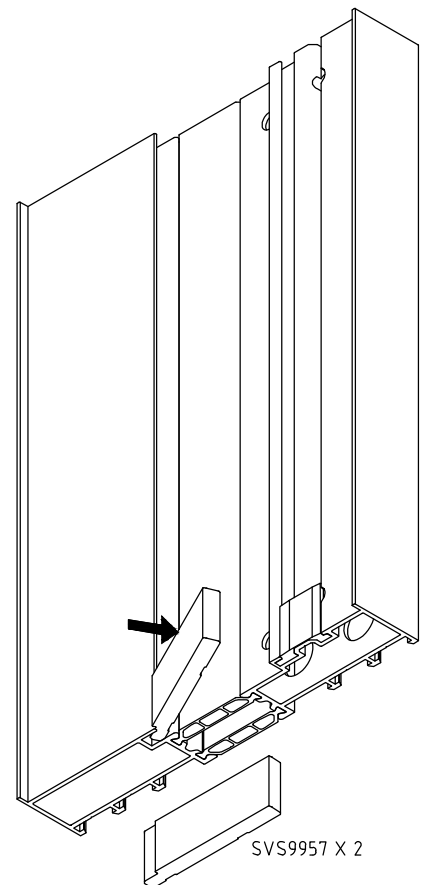
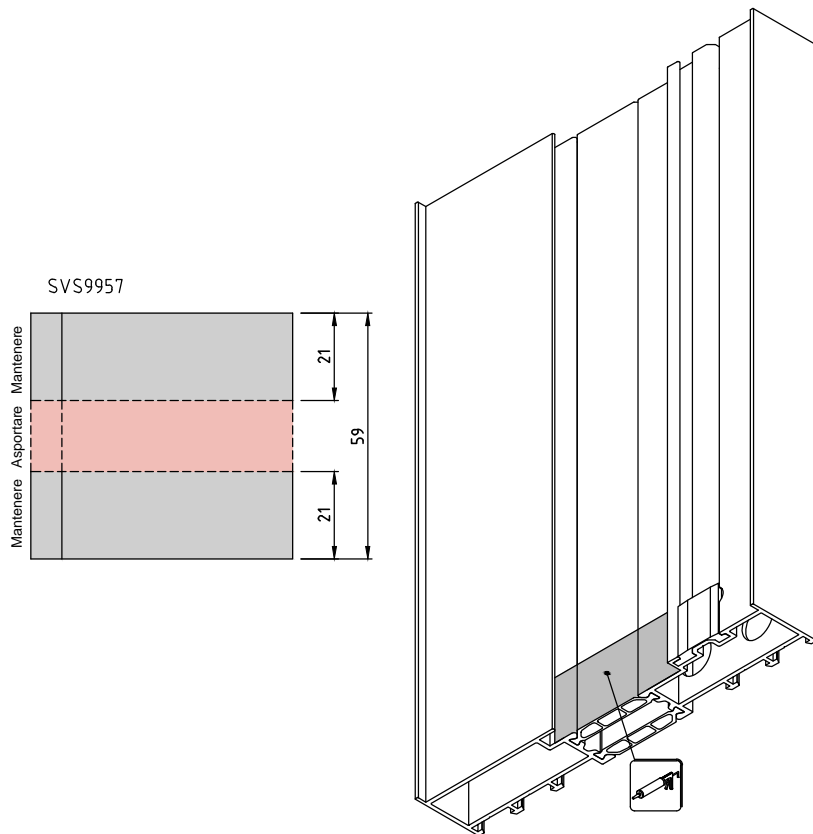
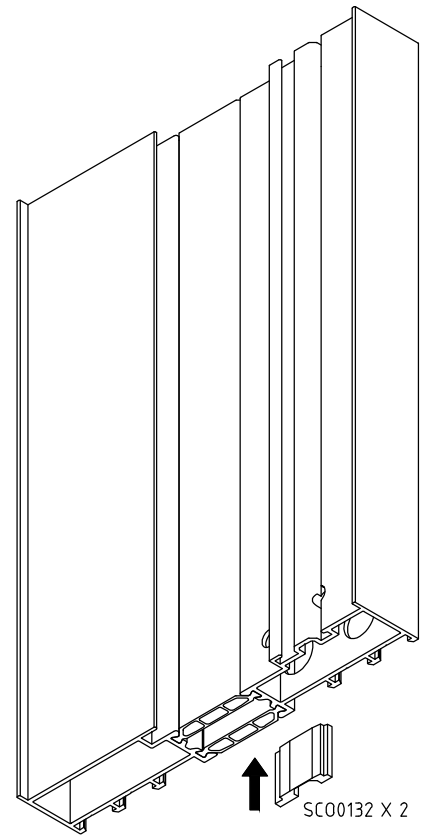
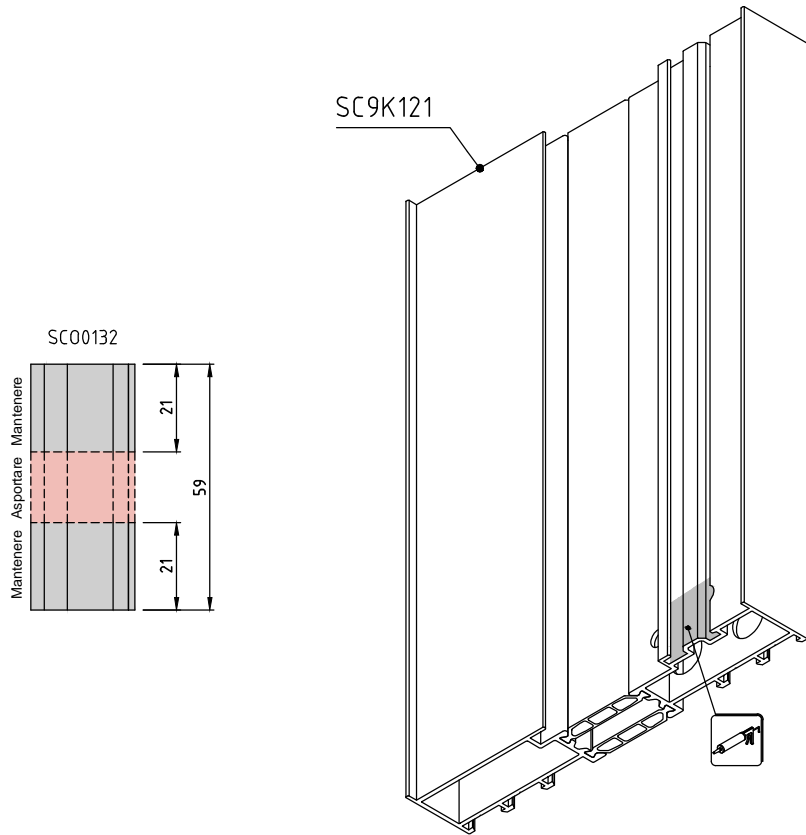

DESCRIZIONE	ACCESSORI	ATTREZZATURA
ASSEMBLAGGIO MONTANTE/TAPPO/SOGLIA D3110002	D4110001 SSCA604	

